

Independent Jaguar Spares Specialist

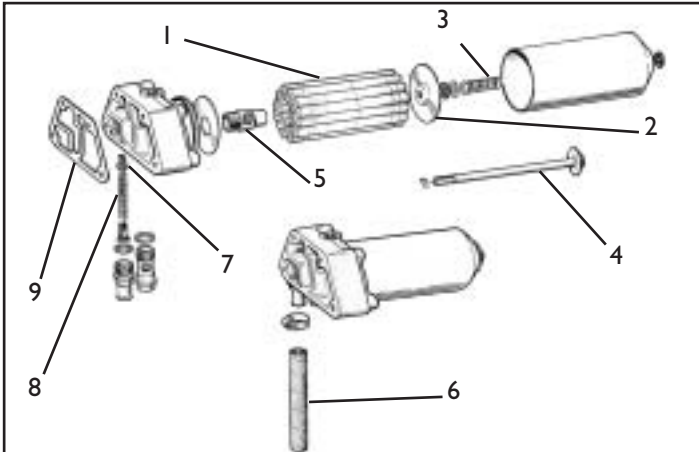

XK Type Engine Cannister Oil Filter

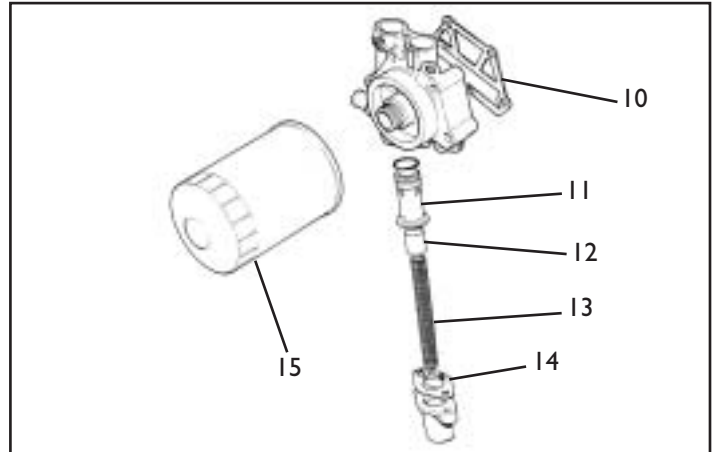

XK Type Engine Spin Off Oil Filter

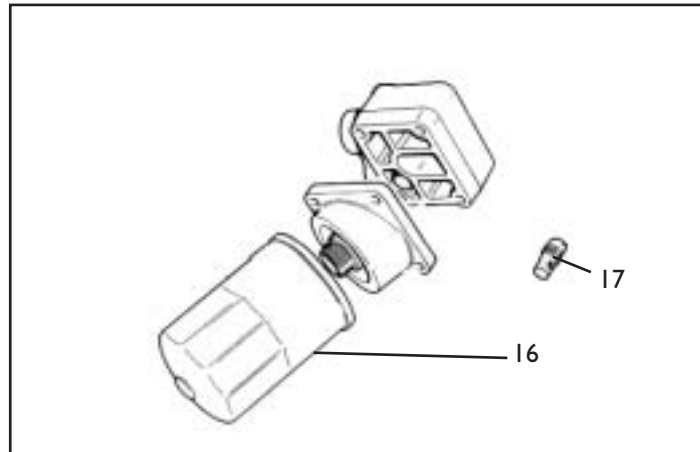

AJ6 Engine Oil Filter

12 Cyl Engine Cannister Oil Filter

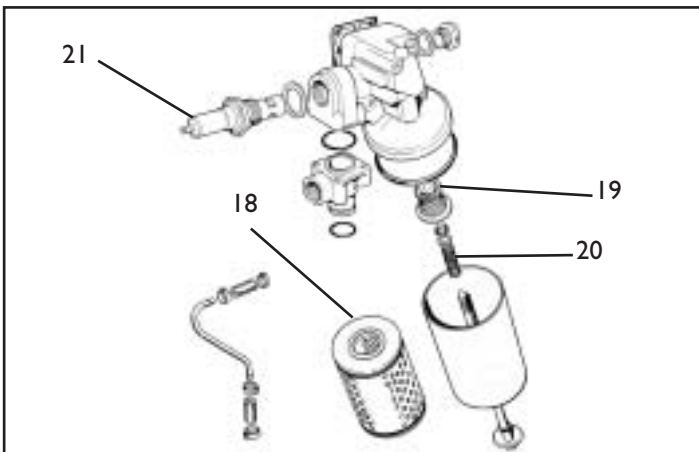

12 Cyl Engine Spin Off Oil Filter

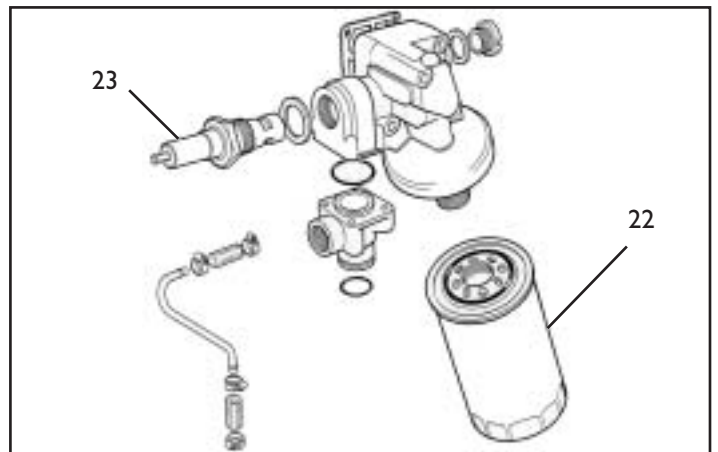

SNG Barratt USA, 92 Londonderry Turnpike, Manchester, New Hampshire 03104, USA.
 Telephone 603-622-1050 Orderline 1-800-452-4787 Fax 603 622 0849
 E-Mail sales.usa@sngbarratt.com Website www.sngbarratt.com



Independent Jaguar Spares Specialist

XK Type Engine Cannister Oil Filter

1. Paper oil filter element

MK7/8/9		FG2421±
XK120	to W4382	1535
	W4383 on	FG2421±
XK140		FG2421±
XK150		JLM9544±
MK2/E-Type/420/S-Type/MK10/420G		JLM9544±
XJ6 S1/2		JLM9546

±Also available in felt add suffix F

We can also provide a spin off oil filter conversion turn to page 254 Performance Modifications section.

2. Retaining plate

MK1/2/XK150/E-Type/420/MK10/420G	6886
S-Type/MK10	
XJ6 S1	11666
XJ6 S2	to 8L9780 & 8L10300
	8L9781 & 8L10301
	AAU1012

3. Retaining spring

MK7/8/9/XK Models MK1/2/ E-Type/420/S-Type/MK10/420G	6159
XJ6 S1/2	2.8 7G1001-7G18942
	4.2 7L1001-7L40865
	2.8 7G18943 on
	4.2 7L 40866
	12962

4. Cannister bolt

E-Type 3.8	8705
XJ6 S1/2	11667
XK150/MK1/2/E-Type 4.2/420	7987
S-Type/MK10/420G	

5. Retaining insert

MK2/E-Type/420/S-Type/MK10/420G	6148 early
MK2/E-Type/420/S-Type/MK10	9348 late

6. Oil filter by-pass hose

XK150/MK1	C12382
E-Type S1/2	C15949
MK1/2/S-Type/420/MK10/ All XJ	C12861
	EAC8531

7. Pressure relief valve

MK1/early MK2/MK7/8/9/XK	7315
Late MK2/E-Type/420/S-Type	8105
MK10/420G	

XJ6 S1	11672
XJ6 S2	JS234

8. Pressure relief valve spring

MK1 early MK2/MK7/8/9/XK	7315
Late MK2/E-Type/420/S-Type	8105
MK10/420G	

9. Oil filter housing gasket±

E-Type 3.8	C15962
E-Type 4.2	C21912

MK2 2.4	BG1001-BG5890	C13091
---------	---------------	--------

BG5891-BG9999	C16301
BH1001-BH7968	

BH7969 on	C20532
-----------	--------

240	BJ1001 on
-----	-----------

MK2 3.4/ 3.8	3.4 KG1001-KG4674	C13091
	3.8 LA1001-LA7449	

3.4 KG4675-KG9999	C16301
3.4 KH1001-KH7062	
3.8 LA7450-LA9999	
3.8 LB1001-LB9999	
3.8 LC1001-LC4264	

3.4 KH 7063 on	C20532
340 KJ1001 on	
3.8 LH4264 on	

S-Type/420	C20532
MK10 3.8/4.2	C19659
XJ6 S1	C29105
XJ6 S2	EAC1542

± If you have problems identifying the gasket on your housing please photocopy it or draw round it and fax it to us, then we should be able to supply it.



Independent Jaguar Spares Specialist

XK Type Engine Spin Off Oil Filter

10. Oil filter housing gasket

XJ6 S2	3.4 8A4596-8A9040	C44277
	4.2 8L28179-8L55926	
	3.4 8A9041 on	EAC1670
	4.2 8L55927 on	
XJ6 S3	3.4 to 8A11903	EAC1670
	4.2 to 8L102220	
	3.4 8A11904-8A15011	EAC2429
	4.2 8L102221-8L157224	
	3.4 8A15012 on	EAC7377
	4.2 8L157225 on	

11. Oil pressure relief valve body	EAC2086
12. Pressure relief valve	EAC1532
13. Pressure relief valve spring	EAC1534

14. Pressure relief valve gasket	
early	EAC1537
late	EAC4178

15. Oil filter	EBC9658(GFE317)
-----------------------	-----------------



AJ6 Engine Oil Filter

16. Bypass valve	EAC2428
17. Oil filter	EBC9658(GFE317)

12 Cyl Engine Cannister Oil Filter

18. Oil Filter Element	
E-Type	C37982
XJ12 S1/2	JLM9547

19. Balance valve	
XJ12 S1/2	JS221

20. Retaining spring	
E-Type	6159
XJ12 S1/2	JS203

21. Oil pressure relief valve	
XJS	RTC1143
E-Type	12914
XJ12 S1/2	C39201

12 Cyl Engine Spin Off Oil Filter

22. Oil filter	EBC9658(GFE317)
23. Oil pressure relief valve	
XJ12 S2/3/XJS	RTC1143



SNG Barratt USA, 92 Londonderry Turnpike, Manchester, New Hampshire 03104, USA.
Telephone 603-622-1050 Orderline 1-800-452-4787 Fax 603 622 0849
E-Mail sales.usa@sngbarratt.com Website www.sngbarratt.com